

Instructions for Working Around Ribbon Splices or Using the Ends of Rolls to Make a Bow

To keep assembly time to a minimum, gather the materials and read through the instructions before beginning.

Working Around Ribbon Splices

Materials:

2 Lengths of Matching Qualatex MasterBow

Ribbon (Both #9 or #40)

Sharp Scissors

Instructions:

1. If you run out of ribbon or come to a splice while making a bow on the Qualatex MasterBow maker, secure the ribbon loops to the RIGHT of the center with a clothespin.

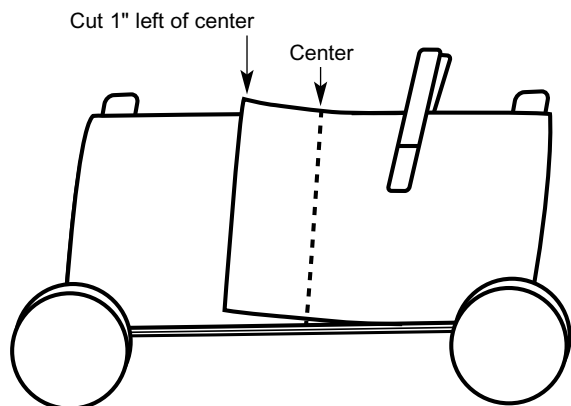

2. Cut the ribbon on both sides of the splice using scissors. Leave about 1" (2.54cm) of ribbon to the LEFT of the center notch area.

3. Overlap the center notch area with the remaining ribbon after splice is removed, or use a new spool if the first one is empty, leaving 1" of ribbon to the RIGHT of the center. **NOTE: Make sure the "cut" ends of the ribbon always cross the center notch area.**

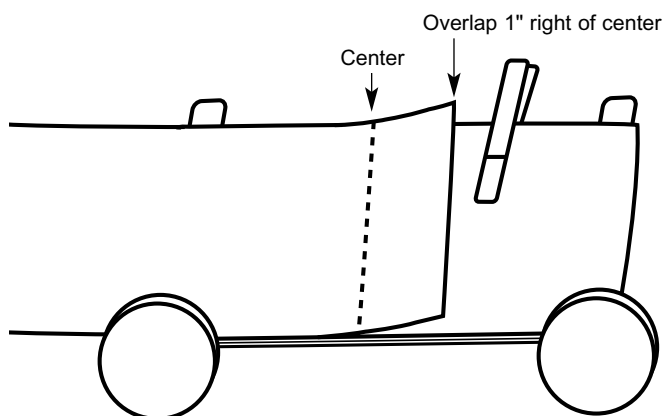

4. Continue winding the ribbon the desired number of turns on the Qualatex MasterBow maker. The ends of the ribbon will be hidden within the loops once the bow is fluffed.

TIPS

To get the most from your ribbon rolls and avoid wasted ribbon, use these instructions to:

- Remove a splice in the middle of making a bow.
- Combine several "short" rolls of ribbon of the same color or design.

